



acaplast  
GROUP

**MATERIAL EXPERTISE AND  
SEALING SOLUTIONS "A LA CARTE"**



# Company Profile

**FAMILY-OWNED SINCE 1958**



**8**  
Production sites  
in Euro-Med zone



**400**  
Employees



**150 MILLION**  
Parts manufactured  
per year



**35 MILLION**  
Annual turnover  
2020



**CERTIFIED**



Team of  
**15**  
in R&D



# Acaplast Approach: Sustainability by Design

## ◆ ACAPLAST ECO PROJECT IN EXTRUDED THERMOPLASTICS:

- ◆ Site uses 90% recycled material to manufacture new products

## ◆ PROMOTING THE USE OF NATURAL AND SUSTAINABLE RAW MATERIALS IN OUR DESIGNS

## ◆ REDUCING ENVIRONMENTAL IMPACT THROUGH:

- ◆ Proximity to our clients to reduce carbon footprint
- ◆ Recycling plant water to limit impact on water resources
- ◆ Sequential plant start-up to reduce electricity consumption

## ◆ ADVANCING CLEAN ENERGY IN THE AUTOMOTIVE INDUSTRY THROUGH COMPONENT DEVELOPMENT FOR:

- ◆ Electric-powered vehicles
- ◆ Hydrogen-powered vehicles (member of AFHYPAC)
- ◆ Hybrid and other alternative energy vehicles

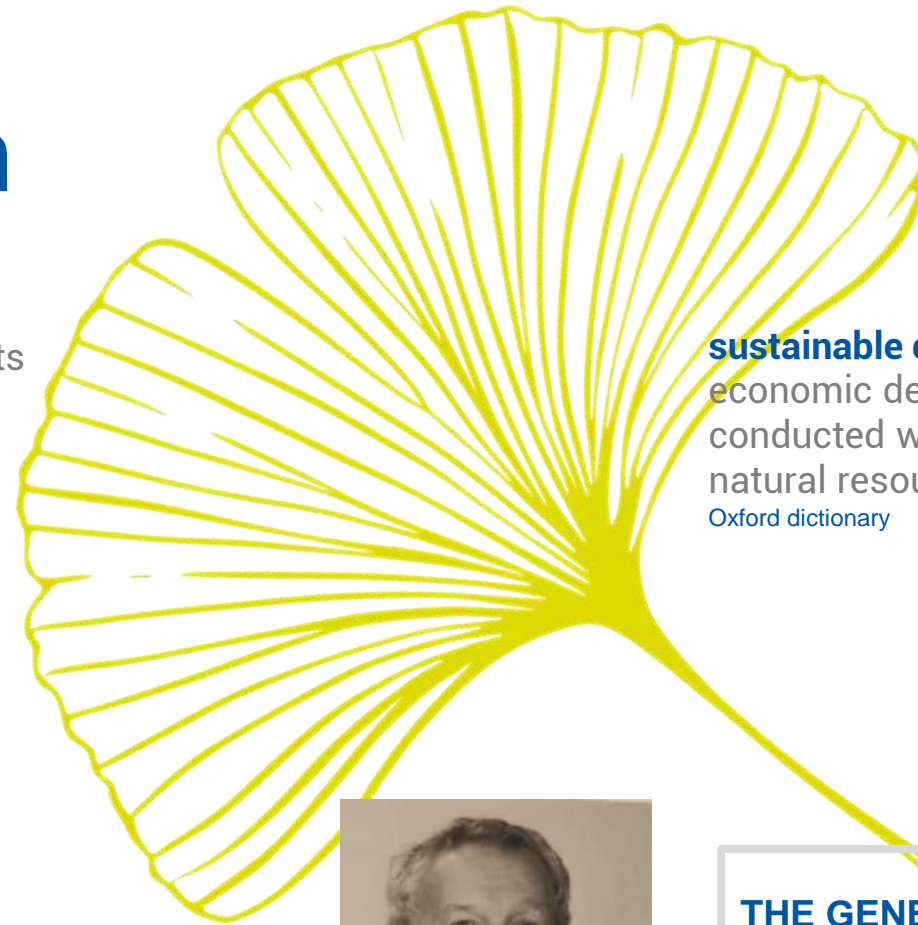

**sustainable development:** *noun*  
economic development that is conducted without depletion of natural resources.  
Oxford dictionary



**THE GENESIS OF ACAPLAST WAS RECYCLING:**

*“The first activity was recycling rubber shoe trim”*



# Acaplast Group History

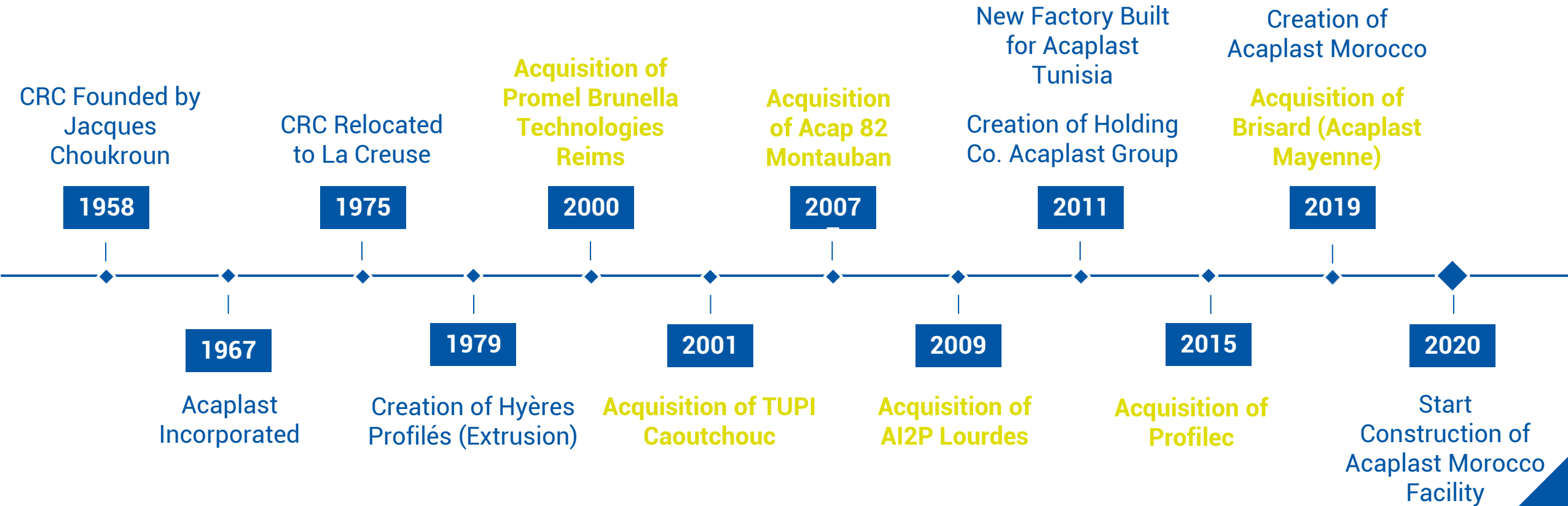

# Acaplast Group Locations

1  acaplast france  
part of acaplast group

2  acap 82  
part of acaplast group

3  pbt  
part of acaplast group

4  acaplast maroc  
part of acaplast group

5  acaplast france  
part of acaplast group

6  ai2p  
part of acaplast group

7  acaplast tunisie  
part of acaplast group

8  acaplast mayenne  
part of acaplast group



# Our Material Expertise

*In-house Rubber Compounding & Injection Molding (15 T to 500 T)*

**CUSTOM-MADE RUBBER DEVELOPMENT**

**ASSEMBLED PARTS**

**We Formulate**

**ACM** **FKM**  
 VMQ  
**FVMQ** **NBR**  
 HNBR  
**NR\*** **AEM**  
**EPDM**  
 \*Bio-sourced option

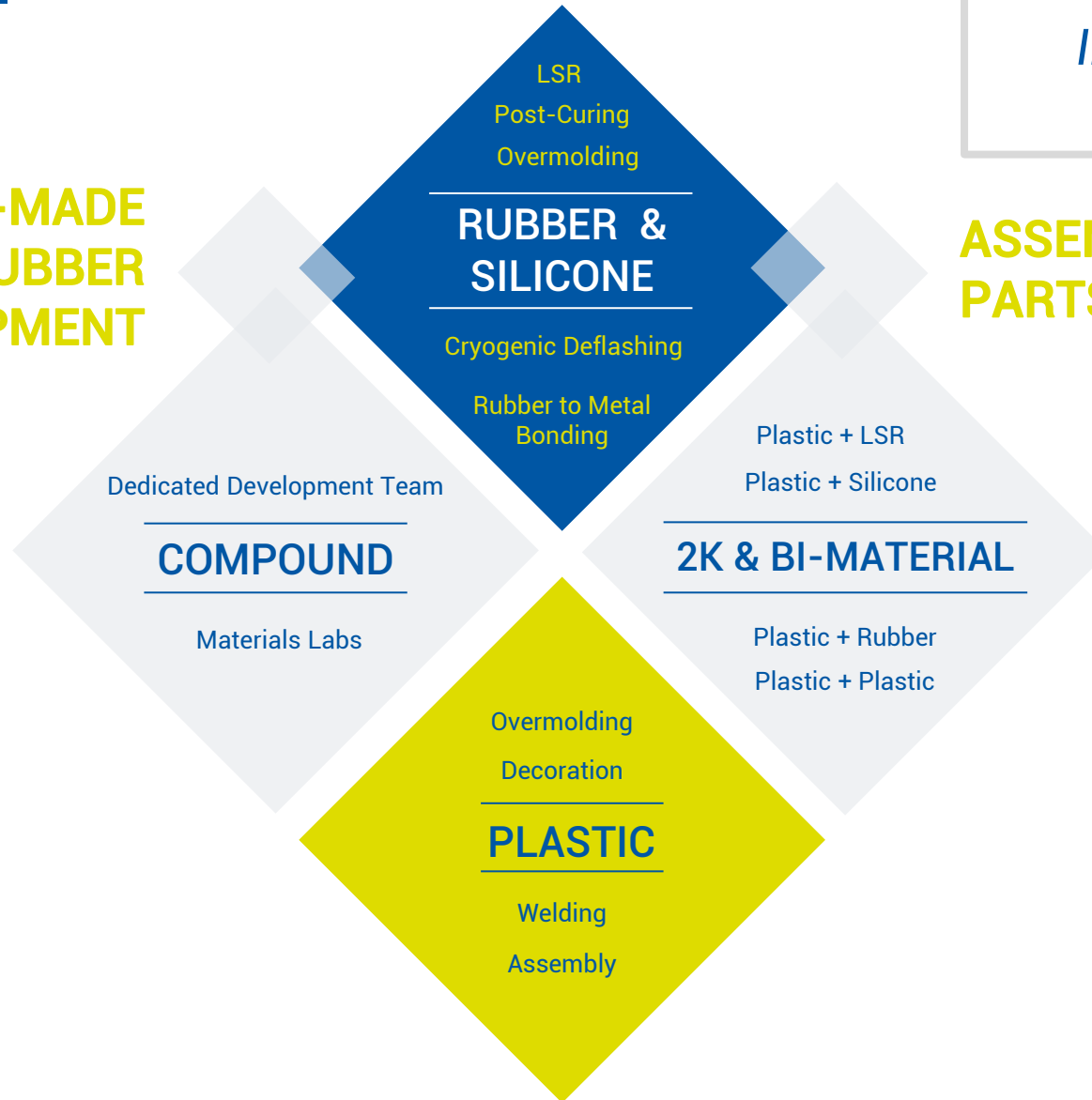

**And Transform**

**ABS** **ABS-PC**  
 PA  
**LSR** **SAN**  
 TPE  
**PP**  
 TPU  
**FLSR** **PC**  
 PE



# Acaplast Provides

## SOLUTIONS FOR YOUR MATERIAL REQUIREMENTS

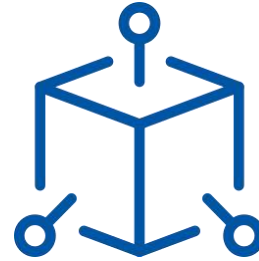

## SOLUTIONS FOR YOUR FUNCTIONAL REQUIREMENTS

- ◆ Impermeability
- ◆ H<sub>2</sub> and aggressive fluid resistance
- ◆ Pressure and high temperature resistance
- ◆ Flexibility and durability
- ◆ Harsh environment resistance
- ◆ Blistering

- ◆ Tightness (H<sub>2</sub>, fluid, air)
- ◆ Endurance
- ◆ Bursting
- ◆ Acoustic performance



# Our Technical Solutions by Design

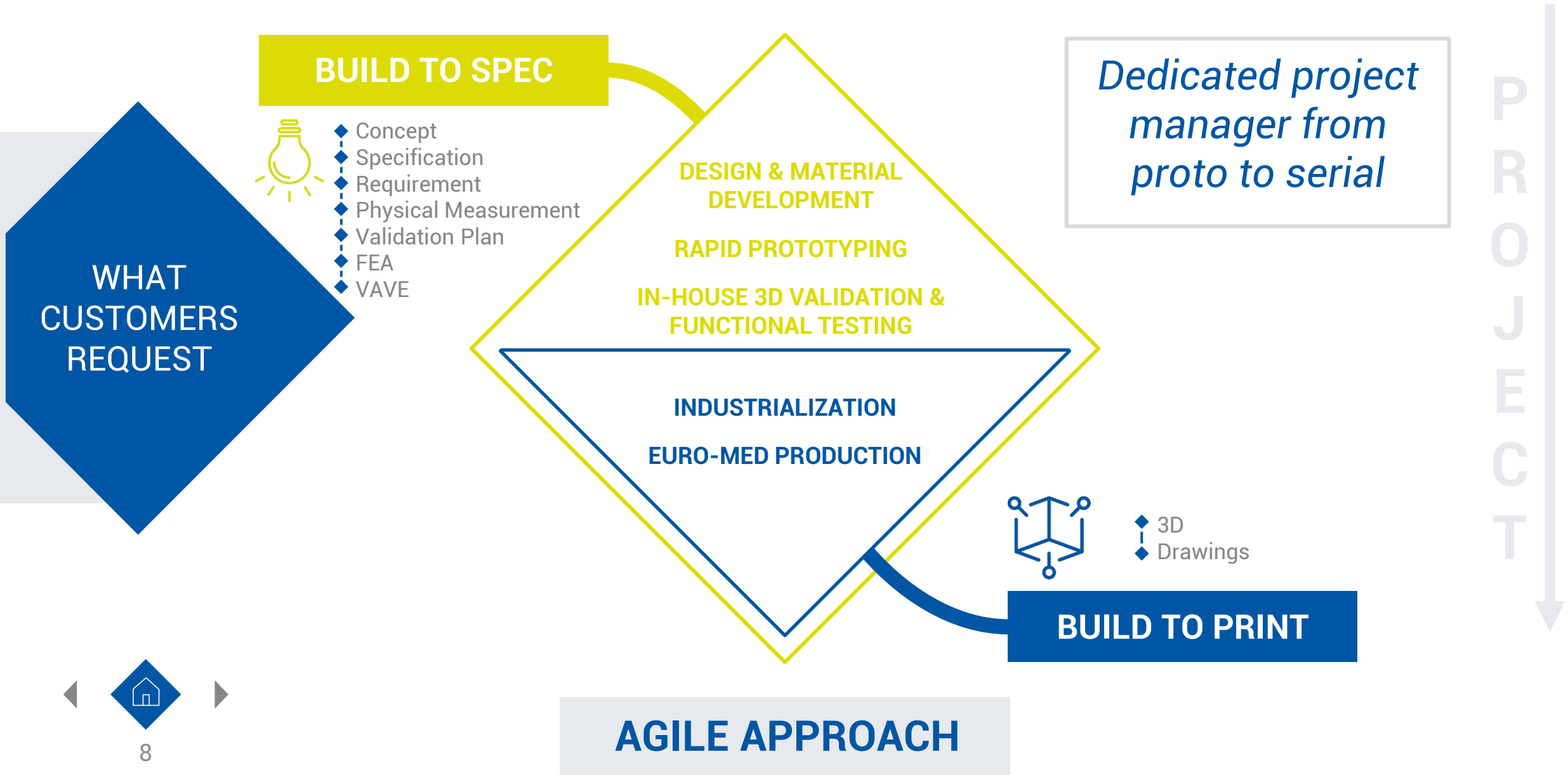

# OUR MARKETS

**MOBILITY**



**PERSONAL  
PROTECTION**



**HOUSEHOLD  
APPLIANCES**



**ENERGY &  
METERING**



**TELECOMS &  
SECURITY**



**COSMETICS**



**SPORTS &  
LEISURE**



**PUMP & FLUID  
MANAGEMENT**



# Mobility

## PROVEN EXPERIENCE IN SEALING SOLUTIONS

- ◆ Custom-made solutions for rubber, plastic and silicone automotive products.
- ◆ Market focus on innovation in powertrain, fuel line and protection.
- ◆ Approach adapted to your ideas and needs: from material to design, from DVP to production.
- ◆ Euro-Med production based on 50 years of French development.

10%

**FUEL & ENERGY**

**ACAPLAST  
INNOVATION**

40%

**PROTECTION**

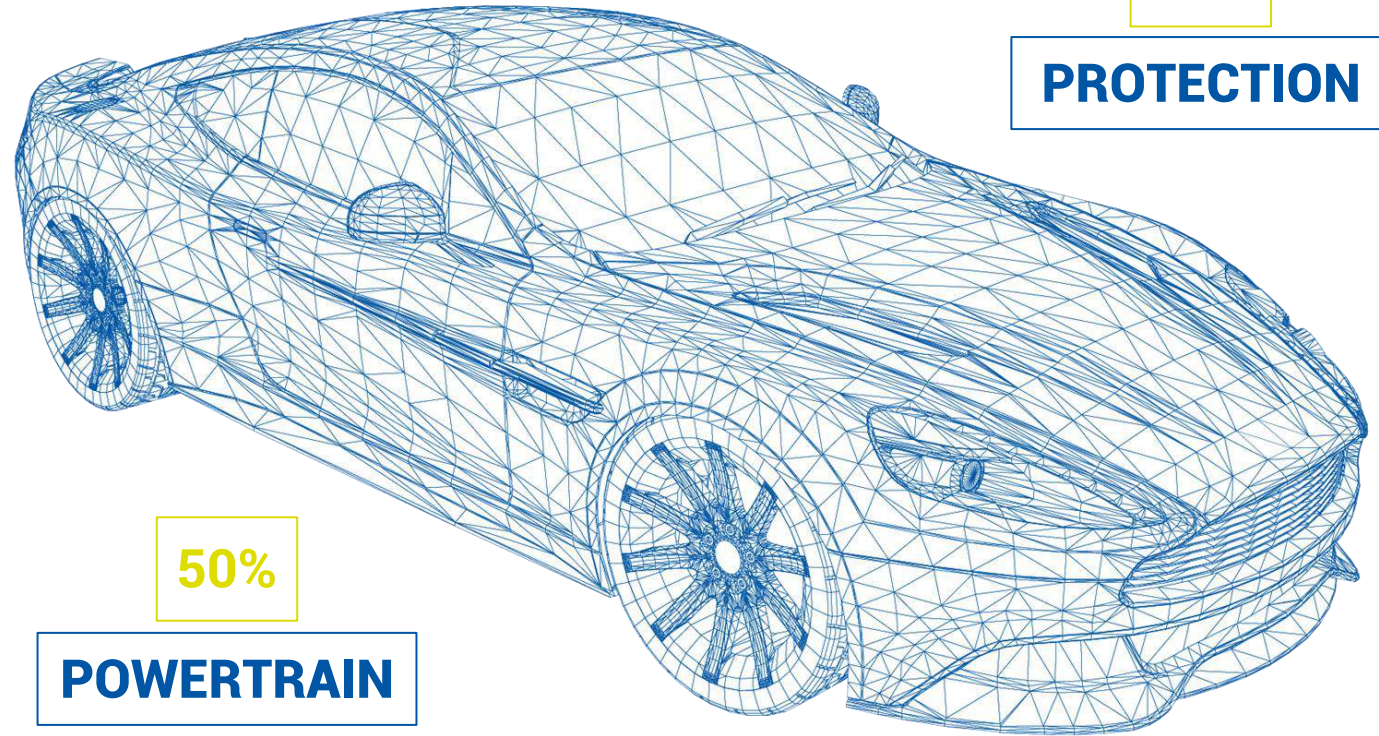

50%

**POWERTRAIN**



# Energy & Metering

## CLIENT FOCUS

- ◆ Global increase in energy demand and changes in the power sector are prompting the evolution of energy production and consumption.
- ◆ New technologies, such as **intelligent meters** and the **smart grid**, aim to optimize the distribution of renewable energy across networks.
- ◆ Acaplast has 20 years of experience in the energy, metering and home automation markets.
- ◆ Rely on Acaplast to produce, source, decorate and assemble your plastic, silicone and rubber metering components and complex subassemblies.

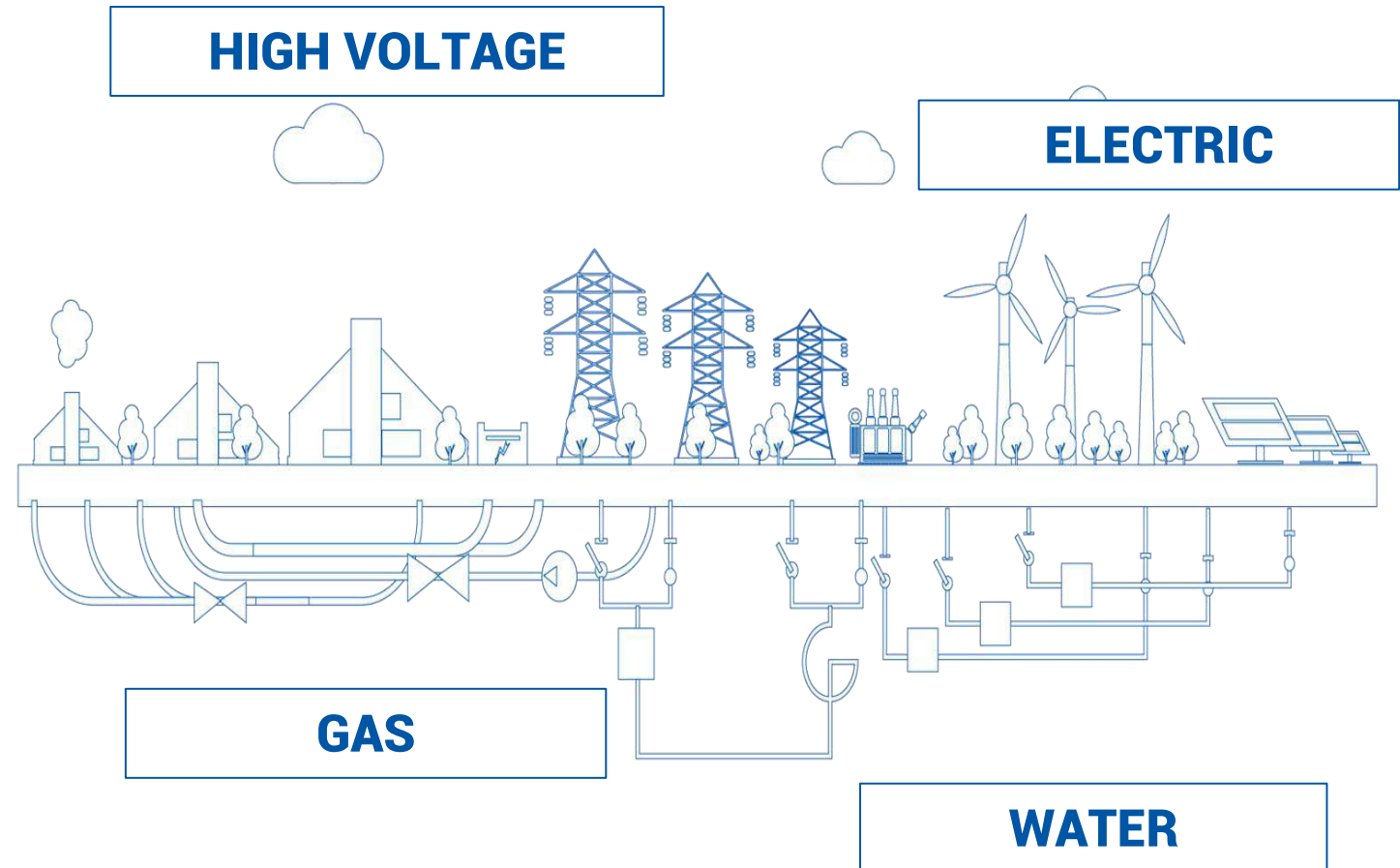

# Pump & Fluid Management

## CLIENT FOCUS

- ◆ Reliable pumps are at the heart of fluid management systems and require watertight seals to ensure the proper functioning and longevity of equipment.
- ◆ Acaplast specializes in sealing solutions for water treatment, filtration, sanitation and metering apparatus.
- ◆ We support customers in piloting projects, and develop and monitor connected systems to simplify management and maintenance.
- ◆ Our development team can create EPDM fittings adapted to all types of pipes to facilitate installation and upkeep of your pumping system.

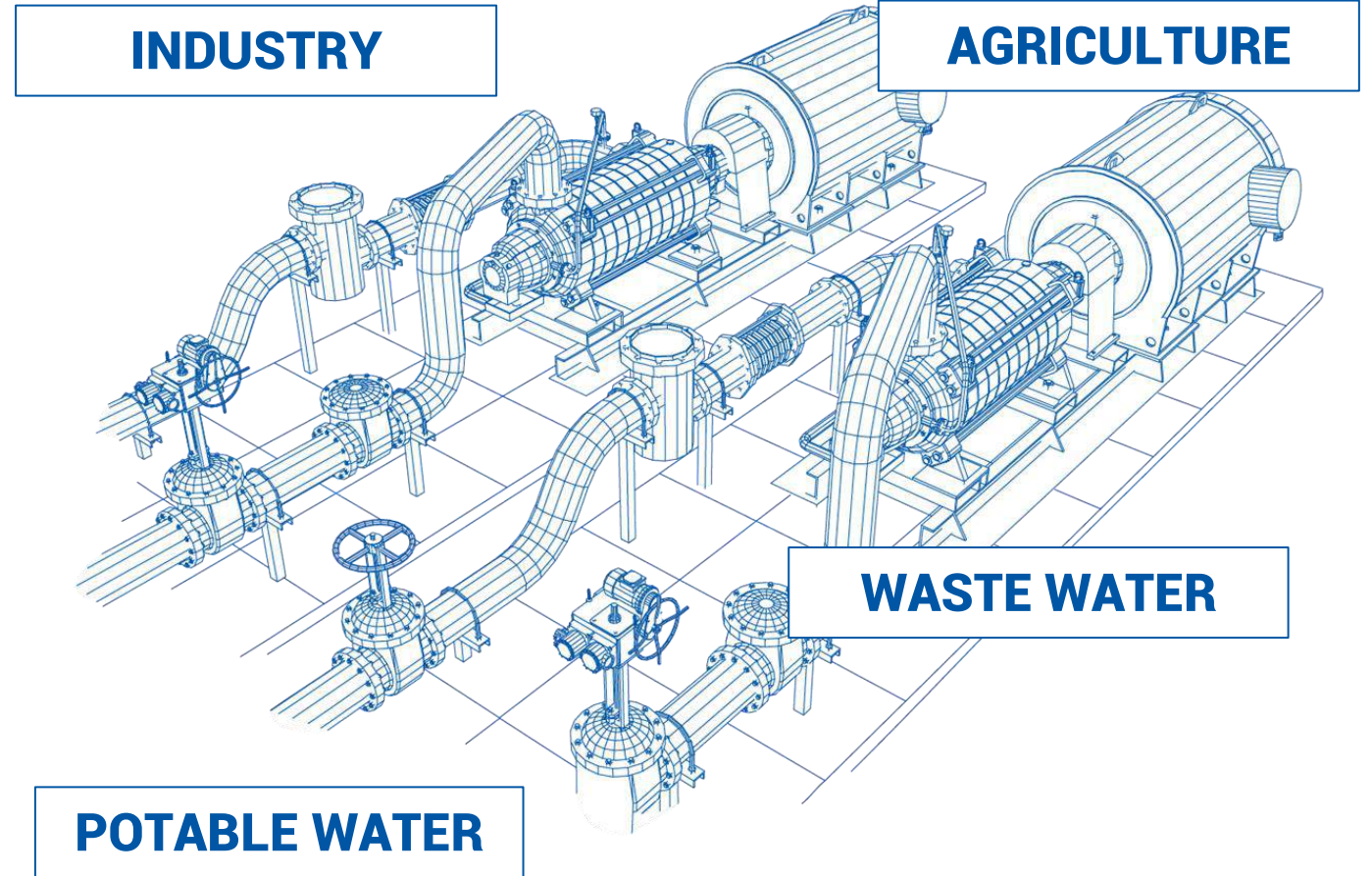

# Acaplast's Experience with Fuel Cell Technology

2006

Acaplast created silicone seals for hydrogen batteries that were employed as backup power at stand-alone telephony towers for a major French gas company.



Hydrogen fuel cells are an efficient, portable energy source suitable for extreme climatic conditions.

2016

Acaplast developed the mold, process and material for an overmolded seal for a hydrogen fuel cell destined for pallet loaders.

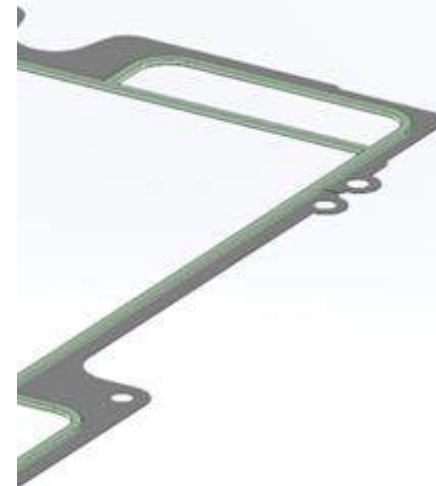

LSR overmolded seals provide electrical insulation and ensure hydrogen, fluid and watertightness between bipolar plates and the membrane electrode assembly (MEA).



# Sealing Solutions for Hydrogen Fuel Cells

## CHARACTERISTICS AND BENEFITS

- ◆ Precision overmolding for uniform sealing on stainless steel and composite materials
- ◆ H<sub>2</sub>, fluid and watertightness
- ◆ Reliability and efficiency
- ◆ Resistance to pressure and high temperatures
- ◆ Electrical insulation
- ◆ Compatibility with automated assembly lines

### Fuel Cell Seal

Material: Silicone + Fiberglass  
Hydrogen Sealing Up to 200°C  
LSR Fiberglass Overmolding  
Lightweight

### Fuel Cell Seal

Material: Silicone +  
Stainless Steel  
Hydrogen Sealing Up to 200°C  
LSR Overmolding





# Product Highlights

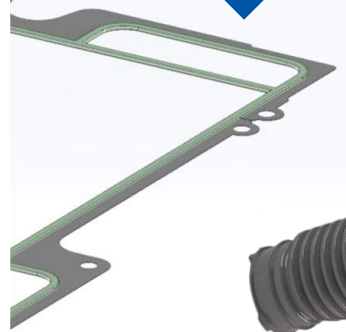

RUBBER & SILICONE

2K & BI-MATERIAL

PLASTIC

COMPOUND

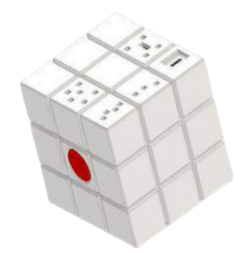

# Innovation: Case Study

## FROM MATERIAL DEVELOPMENT TO COMPONENT PRODUCTION

### CHALLENGE FOR PREMIUM GERMAN OEM:

- ◆ PZEV emissions regulations
- ◆ Crash test safety

### SOLUTION PROPOSED BY ACAPLAST:

- ◆ Re-engineering of existing Acaplast expandable jumper hose
- ◆ Includes FTPV fluorine-based low-emissions liner

### RESULT:

- ◆ German vehicle meets the most demanding standards
- ◆ Vehicle rolled out globally

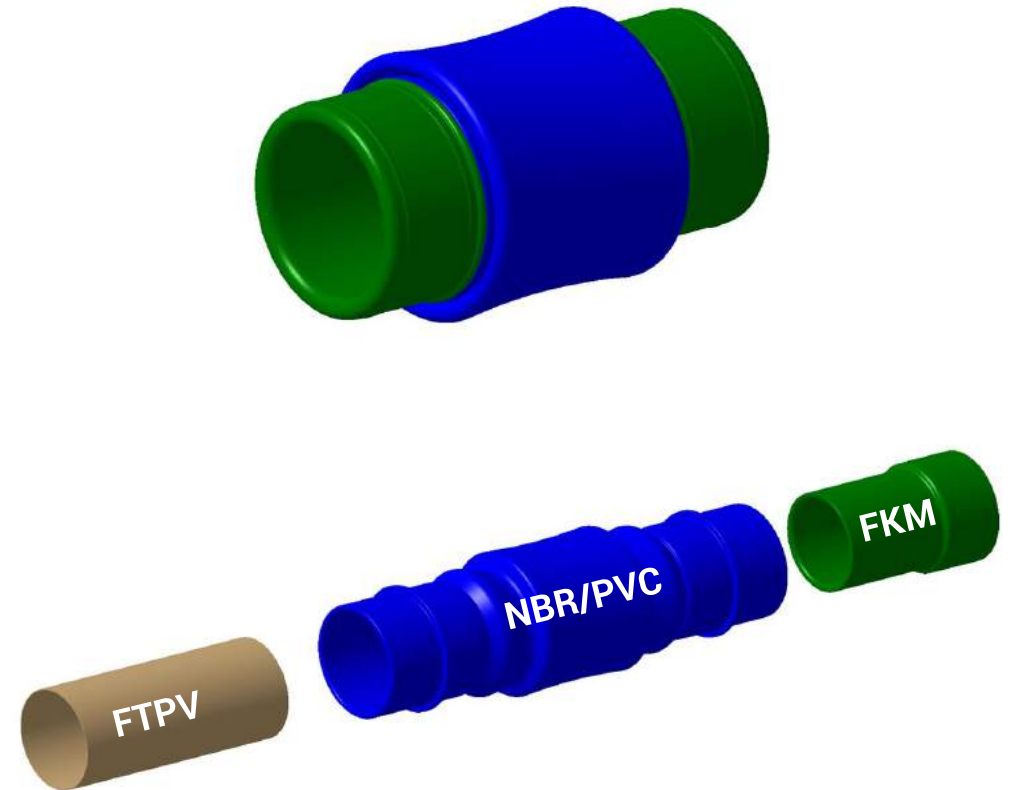

# OUR CLIENTS

## MOBILITY



## PERSONAL PROTECTION



## HOUSEHOLD APPLIANCES



## ENERGY & METERING



## TELECOMS & SECURITY



## COSMETICS



## SPORTS & LEISURE



## PUMP & FLUID MANAGEMENT



# Contact Us

## ACAPLAST FRANCE

*Zone industrielle de Lagette*

*23210 - Bénévent-l'Abbaye*

*Tel: +33 (0)5 55 81 54 32*

*Email: [contact@acaplast.com](mailto:contact@acaplast.com)*

